



# The next generation Pneumatic Riveter **R2A1**





**High endurance**  
Hydraulic oil filling  
required less often

Less than 0.2 mm stroke loss  
after 1,000,000 strokes

**Hard ergonomic grip**

Easy to hold and maneuver  
without slipping

Rounded edges

Lightweight 1.25kg

Designed for  
work-friendly use

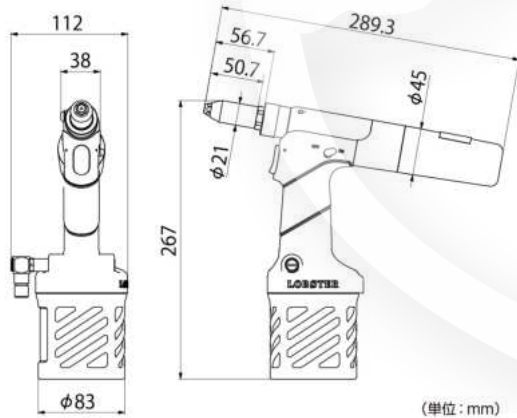

(單位 : mm)

**Improved functionality**



Amply long stroke despite  
the compact size of the riveter.



The 2-color elastomer resin grip  
can be held in either hand  
without slipping or causing fatigue.



The R2A1 has air supply ports  
on both sides that users can  
interchangeably use to accommodate  
work shape and process.

**Improved safety**

**Protective cover  
on cylinder cup**  
Equipped as a standard feature,  
this protective cover reduces  
the chances of damaging works.



**Mandrel kick-out  
preventing shutter**

As an improved safety feature,  
this shutter reduces the risk of  
mandrels being kicked out  
when the tank case is not mounted  
on the riveter and the vacuum is off.



**TECHNICAL DATA**

Model No	Model No.	R2A1
	Product weight (kg)	1.25kg ※1
	User range	$\Phi 2.4$ 、 $\Phi 3.2$ 、 $\Phi 4.0$ 、 $\Phi 4.8$ 、( All types listed in Lobtex catalog ) ※Optional support : high-strength rivets NSTB
	Stroke (mm)	19 mm
	Used air pressure MPa	0.5 ~ 0.6 MPa
	Output	9.0kN ( Traction power at 0.6 MPa )
	Sound	Pressure level ( Lpa ) 75dB
	Air Consumption	Max. 82 L/min (Suction at 0.6 MPa)
	JAN Code	4963202004855
Package Item	nosepiece ( $\Phi 2.4$ 、 $\Phi 3.2$ 、 $\Phi 4.0$ 、 $\Phi 4.8$ ) , guide pipe ( $\Phi 2.4$ 、 $\Phi 3.2$ ) Guide Pipe Collar ( $\Phi 4.0$ 、 $\Phi 4.8$ )	